



# Audio Engineering Society Convention Paper 5385

Presented at the 110th Convention  
2001 May 12–15 Amsterdam, The Netherlands

*This convention paper has been reproduced from the author's advance manuscript, without editing, corrections, or consideration by the Review Board. The AES takes no responsibility for the contents. Additional papers may be obtained by sending request and remittance to Audio Engineering Society, 60 East 42<sup>nd</sup> Street, New York, New York 10165-2520, USA; also see [www.aes.org](http://www.aes.org). All rights reserved. Reproduction of this paper, or any portion thereof, is not permitted without direct permission from the Journal of the Audio Engineering Society.*

---

## The Active Listening Room Simulator: Part 1

Amber Naqvi (1)  
Francis Rumsey (2)

(1) Institute of Sound Recording  
University of Surrey, Guildford GU2 7XH, UK

(2) Institute of Sound Recording  
University of Surrey, Guildford GU2 7XH, UK

### 1. ABSTRACT

The main objective of the 'active listening room' project is to design a critical listening environment where the key acoustic features of the room can be actively modified. The aim is to create a truly variable listening condition in a reference listening room by means of active simulation of key acoustic parameters such as the early reflection pattern, early decay time and reverberation time. These parameters are likely to affect the subjective assessment of reproduced sound quality in a listening environment. Aims of the project are described, together with results of preliminary experiments.

### 2. INTRODUCTION

The basic idea of an active listening room is based on the theory of auralization, where a known sound field is simulated by re-producing the key acoustic features of a given environment in an acoustically controlled listening environment. Traditionally, this is done by the convolution of an impulse response of the environment to be simulated, through a DSP engine, with "dry" program material. Listening is done on headphones or in an anechoic chamber. With the standardization of reference listening room, such as the ITU-R BS 1116 [1], where the reverberation time and early reflection patterns are controlled within critical limits for a given shape and size of the room, it is considered that the simulation of artificial sound fields should be possible by strategically arranging multiple active sources around the listener position. This will give another dimension to the acoustic properties of such listening environments where a listening test can be carried out in a variety of acoustic conditions. One of the specific aim of this project is to design a listening area where the acoustic parameters can be varied to simulate a slightly different listening conditions for specific listening tests. This is in recognition of the fact that there are slight differences in the various standards such as the ITU-R 1116, IEC 286-13 [2], EBU R22 [3], OIRT Rec. [4] and the Nordic Rec. [5].

Traditionally, experiments in the field of simulation of sound fields are carried out in anechoic chambers where 95% of the source sound energy is absorbed and is considered a completely inert acoustic environment. A reference listening room on the other hand is designed to resemble a domestic listening room with controlled acoustic characteristics. However, it is a fact that any listening environment, including a reference listening rooms, has its own acoustic characteristics which makes it subjectively quite different from any other. Although complying with a given standard, the sound field of a reference listening room is far from being considered acoustically inert. This variation in the subjective and objective domains is the basis of the active listening room where the key acoustic features such as the reverberation time, early decay time and the early reflection pattern can be varied during specific listening tests to subjectively assess the effect of change in listening conditions on the results of the tests.

Our initial efforts in the design of an active listening room simulator are concentrated in a study of the reflection-free zone and the simulation of artificial reflections. Research into the effects of early reflections on the perceptibility of direct sound has been going on since the early 50s by Haas[6]. Experiments by Muncey (1951) and

Schubert (1967) have been performed for various kinds of music as well and it was reported that our hearing is less sensitive to echoes in music than in speech. Also at this early stage, it was established that our hearing is more sensitive to reflections coming from the lateral direction than to those arriving from front or back, and that reverberation causes a masking effect at least with continuous sound sources. Seraphim [7] in 1961 reported, for the first time, the threshold of absolute perceptibility of a reflection being added to a sound field consisting of direct sound plus one, two, three and four reflections at fixed delays and at relative levels coming from the direction of the primary source. Reichardt and Schmidt [8] in 1967 presented results of an experiment in which a synthetic sound field was created with the direct sound, two lateral wall reflections, a ceiling reflection and reverberation. In 1988 Olive and Toole [9] carried out detailed experiments relating to the threshold detection and image shift. Their experiments were conducted in an anechoic chamber, then in a IEC standard listening room [2], in un-treated 'reflective' mode, and finally in the same room in its relatively-reflection-free mode (RRF). A comparison of simulated reflections vs reflections recorded in the original source signal is also presented. Energy-time curve (ETC) measurements were taken at each stage to establish the relationship of such measurements with subjective assessments. They found that discontinuous and continuous sounds exhibit fundamentally different absolute thresholds as a function of reflection delay in different listening conditions. Absolute thresholds of reflections for different source materials in different listening conditions were presented in a graph which has become the benchmark for absolute and relative thresholds of early reflections. The specification of the reflection free zone in the above mentioned listening room standards ( which suggests that the level of any room reflections should be <-10dB within the first 15ms re direct sound ) is primarily based from this study.

Another key research project of recent times in this field was the Archimedes project, which was started in 1987 jointly between B&O A/S, KEF Audio Ltd. and The Technical University of Denmark. The main aim of this project was to investigate by experiments the influences of individual reflections on the timbre of re-produced sound. In the summary of results Bech [10] [11] [12] suggested that only first order ceiling and floor reflections individually contribute to the timbre of the reproduced noise. It is also suggested that the threshold of detection is determined by the spectral changes in the dominant frequency range of 500Hz – 2KHz. The effects on the TD by application of low and high pass filters to individual reflections agreed with the findings of Olive and Toole. Bech also looked at the effects of early reflection on the spatial aspect of reproduced sound in a small room using the same experimental set-up. The results indicate that the spectral energy above 2KHz of the individual reflection, determines the importance of the reflection for spatial aspect, and that only the first order floor reflection is strong enough to contribute separately to the spatial aspect of the sound field.

These findings are used as a basis to investigate the feasibility of using flat panel DML loudspeakers around the source loudspeaker in a series of experiments set-up in a reference listening room. DML panels are chosen for two main reasons:

- 1 - DMLs are rigid flat panels, which can be used as deflectors to deflect sound from the source speaker away from the listener.
- 2 - DMLs have wide dispersion characteristics and their on-axis and off-axis responses are favorable to create artificial reflections in an angular panel arrangement.

The initial experiments involve a single source loudspeaker surrounded by groups of DML panels acting as deflectors to maintain a reflection free zone at the listener position. In turn these panels are excited to create artificial reflection within the designated time window. The location and setting-out of the panels is based on a model to create a pre-defined set of artificial first order reflection

patterns. The experimental set-up and results of objective measurements are presented in the following sections.

### 3. EXPERIMENTAL SET-UP

#### 3.1 The Room

The experiment was set up in a ITU-R BS1116 specification listening room at the University of Surrey. The approximate internal dimensions of the room were 7.35 x 5.33 x 2.50m. Internal room finishes were carpet on floor, lay-in grid tile absorbent ceiling and full range acoustic absorber boxes on the walls. The measured reverberation time was 0.245sec at 1KHz and was found to be within the specified reverberation time window for upper and lower limits in all relevant 1/3 octave bands. The measured ambient background noise level with the ventilation system and technical power switched corresponded to NR12.

#### 3.2 Source Loudspeaker

The chosen source loudspeaker was an active integral amplifier, full range infinite baffle, wide dispersion, medium size studio monitor with an operational bandwidth of 60Hz – 18KHz +/-3dB. The loudspeaker was mounted on a speaker stand and the centre of the cabinet was 1.25m from the floor.

#### 3.3 Deflector Panels

The deflector panels around the source loudspeaker were angled in such a way that any sound hitting these panels was forced away from the listening position. A three-dimensional model of this set-up is shown in Figure 1. The physical size of the panels determines the wavelength of sound waves which can be reflected. Thus, lower frequency sound waves with greater wavelength compared to the panel size will not be deflected by this arrangement. The lower frequency cut-off limit was calculated to be approx. 400Hz. Each of these panels were made up of 18mm thick MDF (Medium density Fibre board) with four 600x600mm cut-outs for the flat panel DMLs. The DMLs were embedded within the rebated recesses so that mounting was flush with the surface of the MDF panel. Figure 2 shows a photograph of the actual physical set-up.

### 4. COMPUTER MODELLING

The experimental set-up was based on a computer model of the panel arrangement around the source loudspeaker which was positioned in the far corner of the room. The reason for positioning the source loudspeaker in the corner of the room was to create a geometric boundary setting which forces the early reflections to be directed away from the listening / measuring position. The computer model of this experiment was created in the commercially available software CATT Acoustic®. The main purposes of creating the model were:

- 1 - To optimise the position of the experiment set-up in terms of angles and positions of the panels to create a reflection free zone at the listener / measurement position.
- 2 - To predict the reflection patterns of the set-up as a whole, and from the panel arrangement in particular, within the first 20ms time window.

The model was constructed for a closed room with internal elements as floating objects. The absorption coefficients of walls ceiling and floor were adjusted to get a close match between the predicted and measured values of reverberation time. The directivity / dispersion of the source loudspeaker was accurately modeled. The positions of the source loudspeaker and the deflector panels were adjusted for maximum deflection of early reflections away from the listening / measurement position. The predicted early reflection pattern is shown in the CATT Acoustic prediction plot in Figure 3. The plot shows the level and time delay of up to third order early reflections. As stated in [13], most of the second order reflections can be ignored on the basis of the total time delay and natural attenuation with distance. Any reflections with a total path longer than 6.34m will

already be attenuated by at least 10 dB relative to the direct sound by spreading loss. Also, due to the absorbent nature of surrounding room surfaces, any diffused reflections within the 20ms time window will be attenuated to well below the -10dB level.

The model predicted a complete reflection-free zone up to 20ms, with the exception of a single reflection at 12ms which was found to be coming from the spaces around the floor and ceiling deflector panels itself. As this reflection was shown to be 20dBs attenuated re direct sound, it was decided that this was the optimum panel arrangement and was used in the construction of the experimental set-up.

## 5. MEASUREMENT OF EARLY REFLECTIONS

### 5.1. Methodology

The measurement of early reflections is a complex issue. It is well known that the impulse response of a linear, time-invariant system theoretically contains all of the information necessary to specify the system response fully. However, the unavoidable combined time / frequency resolution limits mean that the simultaneous, complete identification of time delay, bandwidth and amplitude of an acoustic event is not possible [13]. It is important to understand the transformation from time domain to frequency domain, in particular the inherent limits of the joint frequency-time space. For the purposes of this experiment it is assumed that a measurement system with well-defined Fourier-Transform windows with time resolution of 1–2 ms and a frequency resolution of about 500Hz will be adequate to measure the room acoustic responses from 1KHz upwards [13]. These are the main frequencies giving rise to the directional information which might be disturbed by early reflections.

Walker describes the two measures of short-time response and the ways of usefully displaying the early reflection patterns [14]. The first is the Energy – time curve (ETC) which is the magnitude of the complex system impulse response, usually taken to represent ‘instantaneous energy’. It presents a useful view of the time domain response in which representation of discrete reflections are easily observed. However, the precise theoretical nature of ETC is seriously disputed [15]. Olive and Toole’s [9] views on ETC measurements of early reflections are far from complimentary. Their experience of the audibility of early reflections compared to ETC is that the most significant visible elements of an ETC are contributed by the high-frequency components in signals. The sharply rising spikes of energy are rapidly attenuated if high-frequency components are removed from the signal, but they change very little if low-frequency components are eliminated. Hence, the audible significance of reflections cannot be evaluated by means of the height of energy spikes in ETC, which therefore can be misleading. The practical consequence of this observation is that, using the peak level of ETC spikes as a measure of the audible importance of room reflections can lead to a serious underestimation of the importance of reflected sounds and normal off-axis response of loudspeakers, which contain less high-frequency energy than direct sound.

The second measure is the three-dimensional Energy-Time-Frequency response (ETF) or the “Waterfall” plot in which the start of the Fourier transform block is progressively shifted in time to produce a series of frequency responses at different times. The time resolution is limited by the length of the transform window. Despite some limitations, this is the most useful representation of reflected sound in time and frequency, and is widely used in the spectral analysis of reflected sound.

### 5.2. Instrumentation

A MLSSA (Maximum Length Sequence System Analyser) measurement system was used to measure the early reflection pattern from the source loudspeaker, at the given listening position as per the experimental set-up described in the previous section. A single ½

inch measurement microphone was used at a distance of 1.50m from the source loudspeaker and at a height of 1.25m from the floor. MLSSA out-put signal was fed directly into the built-in amplifier of source loudspeaker. No external attenuator was used. The microphone input to MLSSA was through a ISO:Class 1 B&K Pre-amplifier with 0dB attenuation.

### 5.3. Sequence of measurements

The first set of measurements were taken with the panels in passive mode i.e. the DMLs were not active. This was to examine the reflection patterns of the panel arrangement at the measurement position. The second set of measurements were taken with the panels in active mode. The MLSSA signal was split into two and was fed to the source loudspeaker and one DML in each 1.35m square MDF deflector panel simultaneously. A time delay of 10ms was used in the DML signal to sufficiently separate the impulse of the source loudspeaker and DML in time. A total of eight measurements were taken and the results are presented in the following sections.

## 6. RESULTS

In this section, measurement results as shown on MLSSA display are presented. Only two out of eight measurements are presented and discussed which are representative of key findings of this experiment.

Figure 4 shows the results of the first set of measurements to verify the extent of the reflection free zone. The ETF plot shows the spectrum of direct sound and reflected sound energy within a 45ms time window. No DML panel was active at this stage and the panels were acting as deflectors only. The first arrival is at approx. 5ms and the first significant reflection is shown at approx. 2.5ms later which is from the top edge of the floor deflector panel. The amplitude of this and other subsequent reflections are well below –20dB, relative to direct sound. This shows a clear reflection-free zone around the measurement position for up to 30ms relative to the direct sound.

Figure 5 shows the spectrum of artificial reflections generated by the DML panels within the reflection free zone. DMLs were activated at different amplitudes from each set of deflector panels with an initial time delay of 10ms relative to the main source speaker. The ETF plot shows that the first arrival from the main source loudspeaker is at approx. 5ms, while the first and subsequent arrivals of DML-generated reflections have an initial offset delay of 12ms (electronic delay + physical distance from microphone).

## 7. CONCLUSION

It is clear from the measurement results that the objectives of this first experiment were achieved, and that the concept of deflector panels with embedded DMLs in an angular panel arrangement around a source loudspeaker fulfils the fundamental requirements of the proposed simulation set-up. Below are the key observations from the measurements:

- 1- It was established and proved by measurements that the experiment set-up and panel arrangement around the source loudspeaker created a reflection-free zone where the level of reflected sound energy was well below the –10dB mark.
- 2- Individual DML panels embedded in deflector panels are capable of generating discrete artificial reflections within the reflection-free zone.
- 3- It was noted that the DML panels, when activated, created early reflections of their own. This can be noted in the ETF in figure 5 which shows the spectrum of individual DML panels with relative delays and a subsequent floor reflection of the panel itself. Although it is well documented in published research from NXT that DMLs have a much diffused reflection pattern when compared with a conventional loudspeaker [16] [17], it is important to further investigate the objective and subjective effects of these reflections. To preserve the integrity of the reflection-free zone while the DML s

are excited, some absorptive material or additional deflectors panels may be required inside the otherwise reflection-free zone to reduce the level of these reflections to an acceptable level.

## 8. FURTHER DEVELOPMENTS

The next stage of the active listening room simulator will concentrate on developing the computer model for a two source speaker (stereo) and five source speaker (surround) listening set-ups. Some work has been done in modelling various panel configurations for a typical stereo listening set-up. Figure 6 shows a three-dimensional model of one possible panel arrangement for stereo simulation in a reference listening room. Results of experiments based on this arrangement will be presented in future publications.

## 9. REFERENCES

1. ITU BS. 1116, Methods for the subjective assessment of small impairments in audio systems, including multi-channel sound systems. International Telecommunication Union, Geneva, 1998.
2. IEC Recommendation 268-13. Sound system equipment, Part 13: Listening tests on loudspeakers. International Electrotechnical Commission, Publication 268-13, 1985.
3. EBU Recommendation R22-1985: Acoustical properties of control rooms and listening rooms for assessment of broadcast programmes. European Broadcast Union, Geneva, 1985.
4. OIRT Recommendation 86/3. Technical Parameters of OIRT reference listening rooms. OIRT Doc. TK-29-116, Prague, 1990.
5. Nordic Recommendation N 12-A. Sound control rooms and listening rooms. Technical Recommendation from the Nordic Broadcast Corporations, 1992.
6. H Haas, The influence of a single Echo on the audibility of Speech. AES journal, vol. 20, pp. 146-159, March 1972.
7. Seraphim, H.P., Acustica, 11 (1961) 80.
8. Reichardt, W. & Schmidt, W., Acustica, 18 (1967) 274.
9. Sean E. Olive and Floyd E. Toole, The detection of reflections in typical rooms. AES convention 85 – 1988, re print no. 2719.
10. Soren Bech, Timbral aspect of reproduced sound in small rooms, I. JASA Vol. 97 March 1995.
11. Soren Bech, Timbral aspect of reproduced sound in small rooms, II. JASA Vol. 99 June 1996.
12. Soren Bech, Spatial aspect of reproduced sound in small rooms, JASA Vol. 103 January 1998.
13. R Walker, A controlled – reflection listening room for Multi-channel sound. AES convention 104 – 1998, re print no. 4645.
14. R Walker, Early reflections in Studio Control Rooms: the results from the first Controlled Image Design Installation. AES convention 96 – 1994, re print no. 3853.
15. Vanderkooy, J. and Lipshitz, S.P, Uses and abuses of the energy-time curve. J.A.E.S., 38,11, November 1990.
16. Neil Harries, Sheila Flanagan and Malcolm O.J. Hawksford, Stereophonic Localization in the presence of Boundary Reflections, Comparing Specular and Diffuse Acoustic Radiators. AES convention 104 – 1998, re print no. 4684.
17. Peter Mapp, Henry Azima and Vladimir Gontcharov, The Complex Loudspeaker-Room Interface, Some Further Insight. AES convention 107 – 1999, re print no. 5059.

10. FIGURES

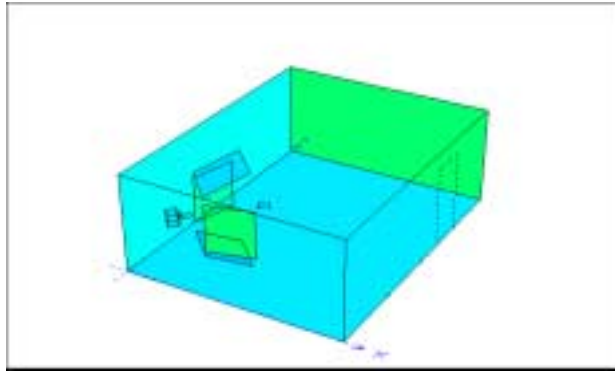

**Figure 1**  
**CATT Acoustic® model plot of experimental set-up**  
 A0 = source loudspeaker, O1 = measurement position  
 4no. 1.3m x 1.3m picture frame panels with 4 DML speaker embedded in each panel



**Figure 2**  
**Experimental set-up in LR1, University of Surrey**

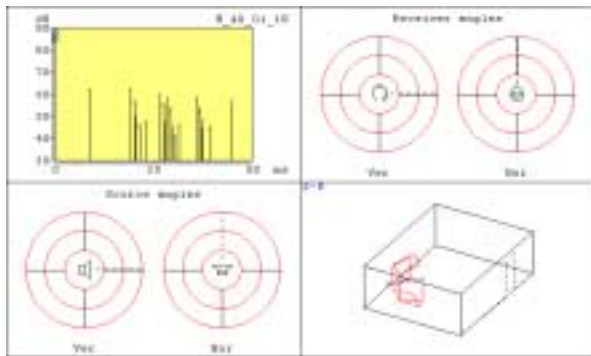

**Figure 3**  
**Predicted early reflection patterns from CATT Acoustic® model**

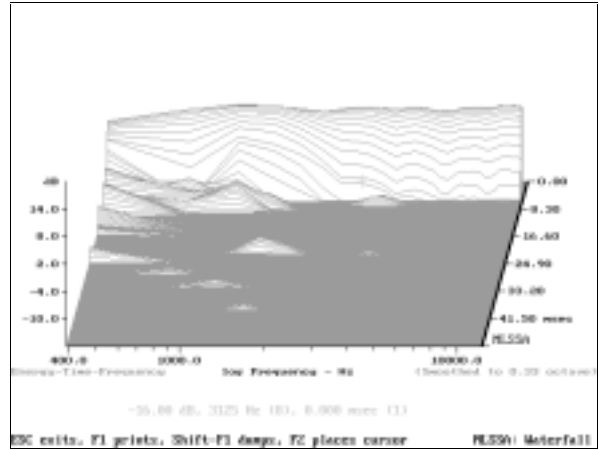

**Figure 4**  
**MLSSA ETF plot of the reflection free zone**

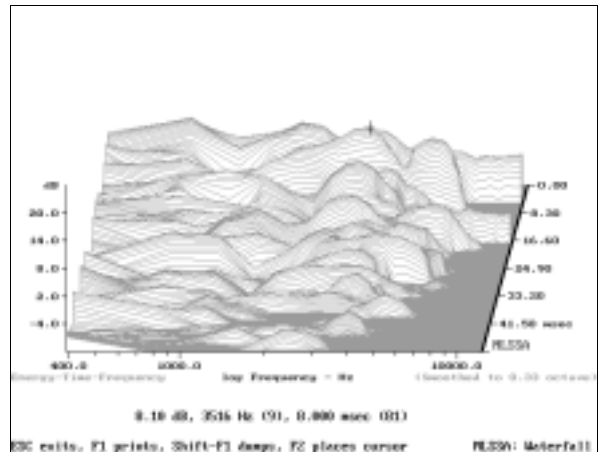

**Figure 5**  
**MLSSA ETF plot of artificial DML reflections**

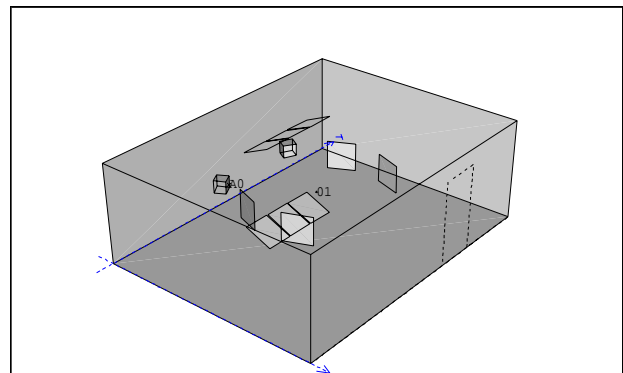

**Figure 6**  
**CATT Acoustic® model plot of the proposed stereo simulation set-up**